

LASER 2000

Rigging Manual

1. Glossary
2. Sail Number Positioning
3. Rigging and raising the mast
4. Rigging the Trapeze
5. Boom and Gnav
6. Jib
7. Gennaker
8. Mainsail
9. Outhaul
10. Cunningham
11. Reefing the Mainsail
12. Rudder
13. Launching
14. Laser 2000 Capsize Technique
15. Maintenance and Service
16. Cordage Lengths

LASER 2000 Rigging Instructions

The Laser 2000 rigging instructions are a guide to rigging your boat. LaserPerformance reserves the right to make design and/or specification changes to any of their products as part of their continuous development program.

Important information

There are three hatches and one transom drain bung on the Laser 2000. Every time you sail, these must be checked to ensure they are closed tightly and fit correctly.

1. Hatches 1 & 2 are found at the aft edge of the foredeck. (Fitted to facilitate additional on the water storage only). (figure 1)
2. Hatch 3 can be found on the inboard surface of the stern deck. (figure 2)
3. The transom drain bung can be found below the lower rudder gudgeon. (figure 3)
4. Example of INCORRECT hatch fitting:

NB: Correct fitting of the transom drain bung and hatch 3, is fundamental to on the water safety and performance of the Laser 2000. (figure 4)



figure 1



figure 2



figure 3



figure 4

1. Glossary

Bow: Front of the boat
Stern: Back of the boat
Fore: Forward
Aft: Rearward
Clew: Back lower corner of a sail
Tack: Forward lower corner of sail
Head: Top corner of sail
Luff: Forward edge of the sail
Foot: Bottom edge of the sail
Leech: Rear edge of the sail
Burgee: Wind direction indicator (usually a small flag)
Batten: A thin stiffening strip in the sail to support the leech
Mast: Main vertical spar supporting the rig/sails
Boom: Spar at the bottom of the mainsail
Gennaker pole: The pole that extends from the bow to fly the gennaker sail
Clear: A fitting used for holding /securing lines
Forestay: The wire supporting the mast at the bow of the boat
Shrouds: Wires that hold the mast in the boat and support it from ¼ up and out to hull side; they attach with shroud adjuster to shroud anchor point
Lower shrouds: Wires that tie off ¼ up mast and shackle to shroud anchor points

Jib: Front sail
Sheet: Rope for controlling the inward/outward position of the sail
Gennaker: Isometric sail hoisted when sailing downwind
Gunwale: The outermost edge of the boat
Gudgeon: Fitting on the transom and rudder used to hang rudder
Cunningham: Purchase system for tightening the forward edge/luff of the sail
Gnav: Purchase system for tightening the rear edge/leech of the sail
Vang (kicker): Otherwise known as the kicking strap or Gnav
Outhaul: Purchase system for tightening the bottom edge/foot of the sail
Halyard: A rope or wire used to lower or hoist sails
Mast heel: Fitting on the bottom edge/foot of the mast
Mast step: Fitting on the boat where the mast heel/foot of the mast is located
Spreaders: Metal struts placed in pairs to support the mast side ways and control the bend in the mast
Stem fitting: Stainless fitting at the bow to which the forestay attaches
Rudder: Blade and attachments used for steering the boat

Useful Boat Terminology

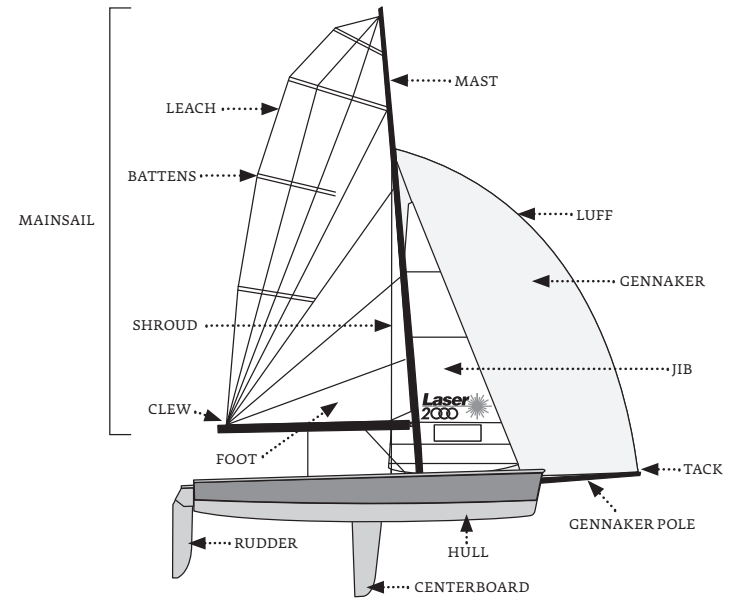

2. Sailing Number Positioning

It is advised to apply the sail numbers in a dry, clean and wind-free environment.

1. Lay the sail on a flat surface starboard side up.
2. Numbers on the starboard side of a sail are always higher than those on the port.
3. Mark a parallel line 76 mm above the third batten down from the head of the sail.
4. Mark a point on the line 76 mm in from the leach.
5. The first number in the sequence should be positioned on the parallel line you have drawn commencing 76 mm in from the leach.
6. Subsequent numbers should be spaced 60 mm apart.
7. Turn the sail over and position the port numbers 76 mm below the third batten down from the head.
8. Work backwards, commencing 76 mm in from the leach.

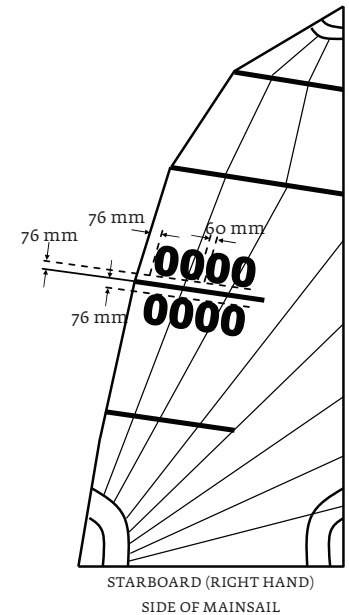

3. Rigging and Raising the Mast

1. Unwrap the mast.

2. Ensure the halyards, shrouds and lower shrouds are led to the gooseneck/base of the mast and each halyard rope end has a knot tied in it. (figure 5)

3. If applicable, fit trapeze wires in the top "T" terminal position on the mast. (Please note: The Laser 2000 trapeze kit is optional and is not supplied as standard) (figure 6)

4. Fit the spreaders. (See next page for diagram.) (figure 7A) (figure 7B)

Tip: Best practice is to fit the clevis pins from above to ensure all split rings are positioned on the underside of the spreader bracket/bars.

5. Ensure that all the spreader pins and rings are taped up or serious damage could occur to the sails. (figure 8A) (figure 8B)

6. Raise the mast and position the mast heel in the center of the mast step. (Note: This is a two person operation as someone will need to hold the mast upright while the shrouds and forestay are connected.) (figure 9)

Caution: Contact with overhead electrical wires could be fatal, exercise extreme caution when raising the mast, launching & sailing.

7. Ensure the mast heel is positioned and engaged correctly as shown. (figure 10)

8. Attach the shrouds to the shroud anchor point with the adjuster pin position in the 3rd hole down on the back of the vernier adjuster. (figure 11)

9. Attach the forestay on to the deck fairlead on the port bow deck as shown. (figure 12)

10. Temporarily fasten the jib and gennaker halyard to the forestay and the main halyard to the port shroud anchor point. (This simply ensures these elements do not impinge upon other activities and are in the best positions for ease of rigging.) (figure 13) (figure 14)



figure 5

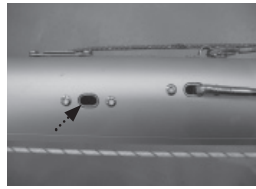

figure 6



figure 7a



figure 7b



figure 8a



figure 8b



figure 9



figure 10



figure 11



figure 12





figure 13

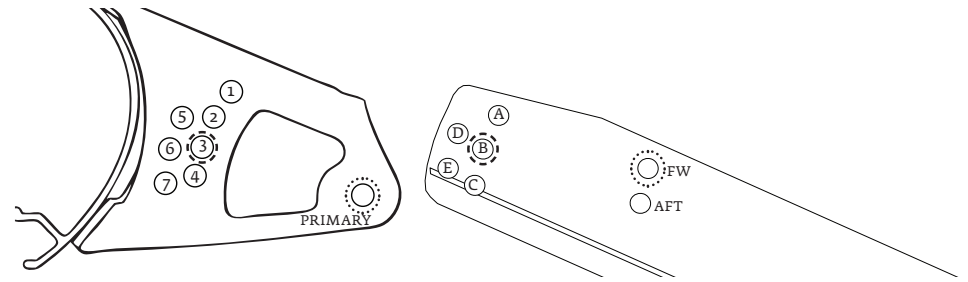
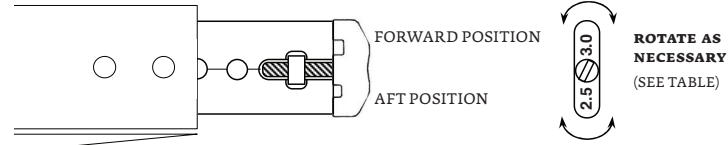

figure 14



Attachment of Spreader.

-  Primary Pin:
Fit down through the bracket's Primary hole and the Forward spreader hole.
-  Adjuster Pin:
Fit down through hole 3 on the bracket and B on the spreader bar.



Spreader Ends

Spreader End Cap:

The spreader end cap incorporates two shroud wire slots to give a tight grip on either 2.5 or 3 mm wire. The sizes are identified on the front face of the end cap (see diagram above). To find which wire slot you require for your mast, please see the table below.

The end cap can also be rotated so that the shroud can be positioned at either the forward or aft position of the spreader end (see diagram above). To find out which position is required for your mast, please see the table below.

To attach the shroud, slacken the end screw, rotate the end clamp if necessary, then insert the shroud. Ensure that the shroud is tensioned between T-terminal and spreader tip, and then tighten the screw firmly.

This method "locks in" the dihedral angle.

Length Adjustment:

Described by the number of adjustment holes visible, (e.g. In the diagram above there are 1 1/2 holes visible). Please see the table below for your class specific positions.

Security

All clevis pins must be fitted with the flat head on top, and locked with a split ring. Tape all split rings, pins and the outboard end of the spreader extrusion. This will reduce chafe on the mainsail and prevent flailing sails/halyards becoming damaged. Self-amalgamating tape is best, but PVC electrical tape is an adequate alternative.

CLASS	BRACKET CONNECTION PIN		OUTER END		
	PRIMARY	ADJUSTER	END CAP POS'N	WIRE DIA.	VISIBLE HOLES
Laser 2000	Fwd	3B	Aft	3.0 mm	0

4. Rigging the Trapeze

Please note: The Laser 2000 trapeze kit is optional and is not supplied as standard.

1. Attach the trapeze wires in the highest T-terminal position on the mast. (Previously covered by "Rigging And Raising The Mast" item 3.)
2. Ensure the trapeze wires hang down the aft face of the mast behind the spreaders.
3. Tie the separate pieces of trapeze shockcord elastic to the respective port & starboard gennaker sock "P" clip attachments behind the jib tack bar. (figure 15)
4. Lead the shockcord elastics down either gunwale towards the respective shroud anchor points. (figure 16)
5. Feed each elastic through the respective shroud anchor points from the inside-out then tie a loop in each as shown.
6. Attach the trapeze rings to hull mounted shock cords by feeding the elastic loop through the ring at the bottom of the pulley. (figure 17)
7. Loop the elastic shock cord over the metal trapeze ring and pull tight. (figure 18)

Tip - Best practice is to tie two double half hitch stopper knots a hand width apart in the adjuster line. (figure 19)

8. Shackle the lower shrouds to the lowest central hole of the shroud adjusters with the shackle facing forward as shown. Ensure that a multiple thickness line of approximately 125 mm in rigged length is used between the shackle and the hard eye in the end of each lower shroud wire.

Please Note: The lower shrouds are part of the trapeze kit and are not supplied as standard. (figure 20)

9. To avoid obstruction, ensure the shackle pins are fitted from the inside out. The better solution would be to discard the shackle pins and replace them with the pan head machine screws that are also supplied. (figure 20)

10. Loosely fasten the other end of the lower shroud wires to the eye on the front face of the mast using multiple thickness line strops. (figure 21)

11. The lower shrouds cannot be tuned and tied off until the jib is hoisted and rig tension is applied, at which point they should be adjusted until both wires are equal, JUST in tension but not pulling the mast aft and tied.

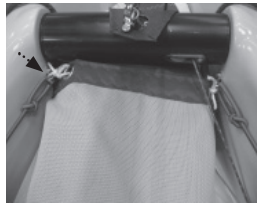

figure 15



figure 17



figure 19



figure 21



figure 22



figure 16



figure 18



figure 20

12. Grip tape should be applied parallel to the gunwale edge commencing approximately 200 mm in front of the shroud anchor points extending aft. (figure 22)

Please Note: The lower shrouds are supplied to support the mast and protect it from the loads applied through use of the trapeze – **the trapeze should never be used without prior fitting of the lower shrouds.**

5. Boom and Vang (Kicker)

1. Unpack the boom.
2. Attach the boom to the mast as shown. (figure 23)
3. Ensure the lower vang (kicker) purchase system is shackled securely to the tang on the lower aft face of the mast. (figure 24)
4. Hook the vang (kicker) upper purchase assembly on to the boom ensuring there are no twists or fouls in the system. (figure 25)
5. Tie the mainsheet through the block on the mainsheet bridle using a half hitch stopper knot as shown. (figure 26)
6. Feed the mainsheet through the blocks and to the mainsheet swivel cleat as shown.

Tip: Double check the mainsheet passes through the auto ratchet in the correct direction shown by the arrow embossed on the side of the auto ratchet block. (figure 27)

7. Vang (kicker) tension is controlled using the aft rope and fairlead/cleats on top of the thwart. (figure 28)

Tip: Best practice is to tie the loose end of the mainsheet to one of the rear toe straps to prevent tangling and the sheet falling overboard. (figure 29)

6. Jib

1. Ensure furling drum line is completely wound onto furling drum before you attach the jib.
2. The furling line/cleat can be found on the starboard side of the foredeck, just in front of the jib sheet track/cleat. (figure 30)
3. Unroll the jib and attach the jib tack to the furling drum using the large shackle provided. (Tape up the shackle and pin to prevent snagging or damage to other sails and lines during sailing.) (figure 31)



figure 23

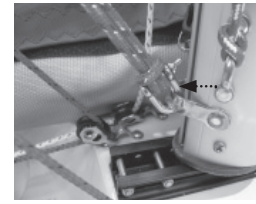

figure 24



figure 25



figure 26 (aft block)



figure 27

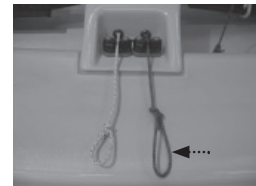

figure 28



figure 29



figure 30



figure 31

4. Fasten the head of the jib to the swivel using the clevis pin and split ring. (Tape up the shackle, pins and split ring to prevent snagging or damage to other sails and lines during sailing.) (figure 32)



figure 32

5. Hoist jib by pulling the white halyard out of aft face of the mast, then hook the jib halyard purchase system onto jib Halyard wire. (Ensure hook is facing aft to prevent it engaging in mast track groove.) (figure 33)



figure 33

6. Tension the jib halyard purchase system until the jib luff wire is taught. (figure 34)



figure 34

7. Cleat and tidy away both rope ends in the halyard pocket positioned on the top of the gennaker sock.



figure 35

Note: If a loose gauge is used to measure the rig tension do NOT exceed 24 units or 150 kg - measured on the shroud 0.75 meters above the vernier adjuster.

8. Find the center of the jib sheet and pass it through the clew of the jib, then pull the two trailing ends of the sheet through the loop you have created to lock them in place as shown. (figure 36)



figure 36

9. Pass one jib sheet to either side of the mast before threading them through their respective port and starboard jib fairleads/cleats. (figure 37)



figure 37

Tip - Best practice is to tie the sheet ends together in the middle of the boat to prevent tangling and prevent sheets from falling overboard. (figure 38a) (figure 38b)



figure 38a



figure 38b

10. Furl the jib by pulling the furling line. The furling line/cleat can be found on the starboard side of the foredeck, just in front of the jib sheet track/cleat. (figure 39)



figure 39

11. **If the trapeze option is fitted:** Now that the rig tension has been applied, the lower shrouds can be tuned. They should be adjusted until both wires are equal, JUST in tension, but not pulling the mast aft, then tied off. (figure 40)



figure 40

7. Gennaker

1. Ensure the end of the gennaker halyard taken from the base of the mast is free of knots and tangles.



figure 41

2. Take the gennaker halyard from the base of the mast and pass forward, under the gennaker sock and round the gennaker pole out-haul block. (The gennaker pole out-haul block is attached to the rope led from the pole as shown in the picture.) (figure 41)



figure 42

3. Thread the halyard aft and through the gennaker halyard cleat/fairlead at the aft edge of the foredeck on the starboard side. (figure 42)

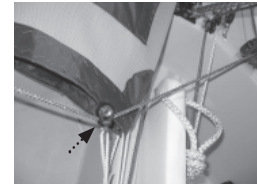

figure 43

4. Pass the halyard across the boat and through the pulley block at the aft end of the gennaker sock. (figure 43)



figure 44

5. Tie the end of the halyard to something such as a batten or tiller extension and carefully pass the end of the halyard up the sock until you can grasp it from the front end of the gennaker sock opening. (figure 44)

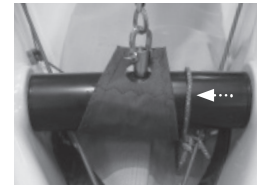

figure 45

6. This is known as the downhaul end of the gennaker halyard and should be temporarily tied around the jib tack bar while the batten/extension is removed from the gennaker sock. (figure 45)



figure 46

7. **Note:** The up-haul end of the gennaker halyard is tied at the base of the forestay from a previous rigging exercise. (figure 46)

8. Unfold the gennaker, identify the tack patch (written on the sail) and securely fasten the tack line to the tack patch using a bow-line. (The tack line comes out of the front of the gennaker pole.)



figure 47

Note: Please check there is also a double half hitch stopper knot in the tack-line and gennaker halyard approximately 100mm prior to the bowline you have tied.



figure 48

9. Identify the head patch (written on the sail), untie the gennaker halyard (up-haul) from the base of the forestay and tie it to the head patch using a bowline. (figure 47)

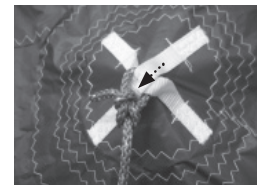

figure 49

10. Untie the gennaker halyard (down-haul) from the jib tack bar:

- Pass through the lower downhaul patch ring on the port side of the sail. (figure 48)
- Secure to the upper downhaul patch using a bowline. (figure 49)

11. Identify the clew patch, (written on the sail) attach the center of the gennaker sheet to the clew of the gennaker. (As per jib sheet to jib clew previously covered in section Sails - Jib) (figure 50)

12. Pass the free ends of the gennaker sheets aft (one sheet either side of the jib luff) and through the gennaker sheet ratchet blocks attached to the shroud anchor points. There are arrows on the ratchet block to indicate which way the rope should pass. When under load, the ratchet will engage. (Note: The sheets must pass forward of the shrouds at all times.) (figure 51)

13. Tie the free ends of the gennaker sheet together. (figure 52)

14. Ensure the boat is pointing directly into the wind and hoist the gennaker. Take great care to ensure that the gennaker does not get snagged around the trolley; a second person should help with this to ensure it does not snag anywhere. Check the gennaker is not twisted and the sheets are not tangled with the halyard.

15. Always take great care to pull up the gennaker slowly and do not keep pulling if it becomes tangled or tight.

16. Unclear the halyard and gently pull the gennaker into the sock by pulling the halyard through the block at the aft end of the sock. A second person should help with this and be positioned at the front of the boat to ensure the gennaker does not get snagged anywhere.



figure 50



figure 51



figure 52

8. Mainsail

1. Remove the mainsail from its bag and unroll.

2. Ensure all battens are tight in their pockets and the locking mechanisms are positively engaged.

3. Position the boat so it is head to wind (bow facing directly in to the wind).

4. Place the mainsail in the cockpit of the hull with the luff closest the bow (front) and the leach closest the stern (back).



figure 53



figure 54

5. Take the main halyard:

a. Ensure there are no twists in the halyard and it is clear of the spreaders.

b. Tie the halyard to the head of the sail using a bowline.

c. Locate the head of the mainsail into the mast track. (figure 55)

6. Hoist the mainsail using the main halyard block/cleat assembly on the lower port side of the mast. (figure 54)

7. Note: Hoisting the mainsail is a two person operation as assistance will be required to feed the mainsail into the mast track while the other person hoists using the halyard. (This will prevent the sail pulling out of the track and jamming which could cause luff rope damage.)

8. When the mainsail is fully hoisted, clear and tidy away the halyard rope end in the halyard pocket positioned on the top of the gennaker sock. (figure 55)

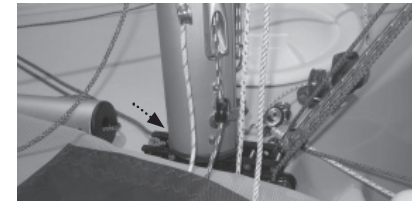

figure 55

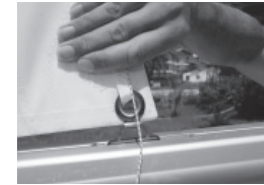

figure 56

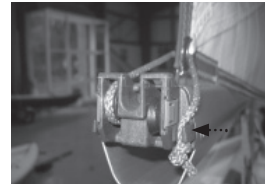

figure 57

9. Outhaul

1. Feed the plastic slug slide on the clew outhaul into the cut out on the top of the boom. (figure 56)

2. The outhaul line is then passed through the lowest eye in the sail (from port/left to starboard/right side) and anchored on the starboard/right side with a simple knot located in the slot formed in the boom end casting. (figure 57)

3. Outhaul tension is controlled using the forward rope, cleat and fairlead at the forward end of the boom. (figure 58)

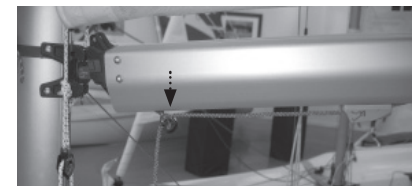

figure 58



figure 59



figure 60

10. Cunningham

1. Pass the rope at the end of the cunningham purchase system through the eye at the bottom of the mainsail luff (from port/left hand to starboard/right hand side). (figure 59)

2. Anchor the end of the cunningham purchase system by sliding a half hitch knot into the mast track just below the gooseneck. (figure 60)

3. Cunningham tension is controlled using the forward rope and fairlead/cleat on top of the cockpit centre console. (figure 61)

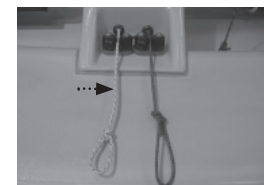

figure 61

11. Reefing the Mainsail

If it is windy and you feel you will be overpowered in the Laser 2000 it is wise to reef the mainsail:

1. Remove the Cunningham from the tack eyelet.
2. Remove the outhaul from the clew eyelet.
3. Slide the clew outhaul slug slide out of the boom track.
4. Unclear the mainsail halyard and lower the mainsail until the upper reefing tack eyelet is around 100 mm above the gooseneck and the foot of the mainsail is just beginning to touch the thwart/sub deck as shown. (figure 62)
5. Roll the sail as tight as possible from the foot onto the port side of the sail keeping the eyelets on the luff and the slug slides on the leach parallel and in line.
6. Feed the original, lower clew outhaul slug slide in to the boom cut out first, followed by the higher reefing slug slide second. (figure 63)
7. Reattach the outhaul control line through the eye attached to the reefing slug slide as shown. (figure 64)
8. Thread the Cunningham line through the three eyelets in the luff of the mainsail and refasten in the slot under the gooseneck.
9. Retension the mainsail halyard if required. (figure 65)

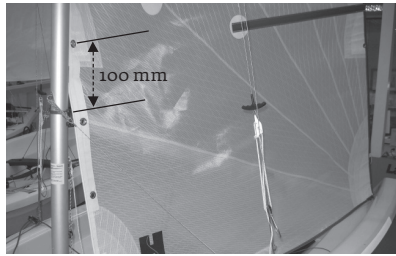

figure 62

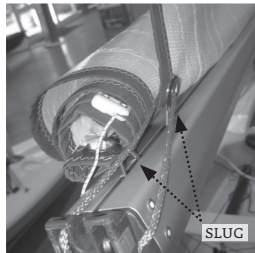

figure 63



figure 64



figure 65

12. Rudder

1. Attach the rudder assembly to the transom:
 - a. Fit the secondary rudder retaining split ring to the top rudder pintle. (figure 66)
 - b. Ensure the primary rudder retaining clip is adjusted and has engaged correctly. (figure 66)

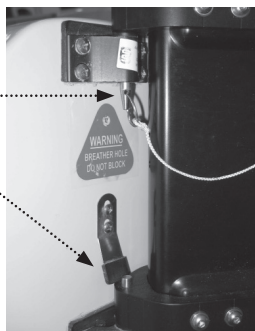

figure 66

13. Launching

- Raise the mainsail with the boat facing into the wind.
- Launch the boat using the appropriate launching trolley.
- Take the boat into the water with the bow facing into the wind.
- Ensure that there is enough water to float the boat off the trolley.
- One person should hold the boat whilst the other gets in and prepares to set off.
- When there is enough water below you, lower the centerboard and rudder fully.
- Cleat the rudder downhaul in the cleat on the tiller and ensure that the wing nut on the side of the rudderstock is tight.

The rudder and centerboard should be in the fully down position at all times when sailing an isometric boat like the Laser 2000.



figure 67

14. Laser 2000 Capsize Technique

The use of a LaserPerformance supplied Laser 2000 mast head float is highly advisable. (This device will assist in the prevention of complete inversion in the event of capsizing).

When sailing your Laser 2000 in breezy or blustery conditions, it is highly probable that from time to time you will capsize. In the event of a capsize we advise you follow the procedure documented below:

Righting the Boat

1. Ensure all members of the crew are accounted for and safe.
2. If the gennaker is deployed, drop the sail back in to the sock.
3. Release the main/jib sheets and vang (kicker) from respective cleats and ensure the sheets are fully extended to avoid the boat sailing immediately after righting.
4. If the boat inverts, first recover the boat onto its side.
5. In adverse conditions and with more than two crew it is recommended that the largest crew member swim to the bow and hold the bow during righting and until all other crew members have reboarded after righting. (This ensures the boat swings in to the safe head downwind position upon righting)
6. It is recommended to use the “scoop” recovery system for crewmembers not involved in the righting procedure. When the boat is on its side, the crew members to be scooped should move to the inner lower side of the boat as close to the center of the boat as possible. As the boat is righted, these crew members will be “scooped” onboard the boat and will then be ready to help others reboard. “Scooping” should only be attempted with practice and should only be commenced after the boat is stabilized on its side by a crewmember who is securely located on the centerboard and holding the capsize righting line under the gunwale. This is to prevent the boat from inverting and potentially trapping the crew.
7. Righting is effected by a crewmember standing on the centerboard moving out towards the end of the board whilst leaning out holding on to the righting line. The boat will recover to the upright position quickly. It should normally only require one average size person to right the centerboard.
8. Immediately after righting the tiller should be pushed fully towards the mainsail to stop the boat sailing until all crew have reboarded.

9. Reboarding can be undertaken over the windward side of the boat using the righting line as a step or over the transom. A grab rail is positioned on the inner face of the sub deck to assist with pulling yourself back in to the boat.

10. If the person in charge of the boat or the crew are inexperienced in capsizing and righting procedures it is advised to practice drills under skilled supervision and in any event, close to assistance prior to the drill being used in earnest.

11. All crewmembers should wear an approved buoyancy aid at all times while on the water.

16. Cordage Lengths

Laser 2000	1 x 6.0 meters, 8 mm, 8 plait, matt, white
Jib sheet	1 x 6.6 meters, 8 mm, 8 plait, matt, white
Gennaker sheet	1 x 9.0 meters, 6 mm, 8 plait matt, blue
Mainsheet Bridle	1 x 2.2 meters, 4 mm, Excel Racing, purple
Cunningham Part 1	1 x 5.0 meters, 4 mm, 8 plait p/s, lime
Cunningham Part 2	1 x 0.8 meters, 4 mm, 8 plait p/s, lime
Kicker/Vang Part 1	1 x 5.5 meters, 4 mm, 8 plait p/s, red
Kicker/Vang Part 2	1 x 2.5 meters, 5 mm, Excel Racing, red
Toestrap Lashing	4 x 0.6 meters, 6 mm, 8 plait p/s, black
Lashing	3 x 0.2 meters, 1 x 0.8 meters, 8 plait, white
Rear Toe-strap Shock-cord	1 x 0.3 meters, 5 mm, Shock cord, blue
Main Toe-strap Shock-cord	1 x 2.0 meters, 5 mm, Shock cord, blue
Righting Line	2 x 1.5 meters, 4 mm, 8 plait p/s, red
Righting Line Shockcord	2 x 0.9 meters, 5 mm, Shock cord, blue
Centerboard Line	1 x 0.75 meters, 8 mm, 8 plait p/s, white

Care, Maintenance and Service of your LaserPerformance Product

Before rigging your boat, read and familiarize yourself with the rigging manual. Failure to adhere to these guidelines could invalidate your warranty.

Maintenance

- Keep the equipment clean by frequently flushing with fresh water. In corrosive atmospheres, stainless parts may show discoloration/brown staining around screw holes and rivets. This is not serious and can be removed with a fine abrasive.
- Excess water should be removed from the hull.
- Ropes, rigging and fittings should be checked at regular intervals for wear and tear, including winch gear.
- All moving parts should be lightly lubricated to avoid jamming, i.e., McLube, dry Teflon or a dry silicone based spray. Do not use oil.
- Inspect shackles, pins and clevis rings and tape up to stop snagging sails, ropes and clothing and to prevent them from coming undone.
- When refastening screws do not over tighten as this may strip the thread and do not reuse Nyloc nuts more than three times.
- Damaged or worn parts should be replaced.
- Sails should be thoroughly washed down with fresh water, dried and stored in a dry place.

Trailers and Trolleys/Dollies

- It is highly recommended that a trolley/dolly is used to launch and recover your boat. Dragging your hull up onto a beach or slip way will wear away the gel coat or polyethylene and damage the boat. Also, the hull should not be left on a pebble beach as the hull skin could be dented.
- Trailers should be rinsed with fresh water and checked at regular intervals. It is recommended that trailers be serviced annually. The trailer and road base should never be immersed in water.
- Trailers and trolleys supplied by LaserPerformance are designed to transport the hull in the best possible manner to avoid damaging the hull. For instance, LaserPerformance does not recommend support hulls on rollers except on the keel line and only where there is a reinforced keelson. We also recommend gunwale hung trolleys for our smaller products. Hulls supported by a trolley bunk or wide strap must have the ability to drain water away from the hull. Trolley bunks padded with carpet or foam can cause blistering in the gel coat and changes to the hull color. Please do not transport your LaserPerformance product on a trailer or trolley that has not been specifically designed for the product. Hulls damaged through using an incorrectly designed or wrongly set up trailer or trolley are not covered under warranty.
- When securing your boat to a trailer for transport be very careful that ratchet straps and ropes are not over tightened and that there is sufficient padding under the strap or rope to prevent the hull/deck from being damaged through abrasion or pressure.
- Top covers must not be allowed to “flap” when driving at speed. This can abrade the surface of the hull and damage it. It is recommended if you are towing and plan to use your top cover that an under cover is fitted first to prevent cover flap damage to the top sides of the hull.
- Repairs to the polyethylene or GRP hulls should be undertaken by persons with the relevant equipment and skills. Contact LaserPerformance for advice.

Storage

- Your boat should always be tied down securely to the ground when not in use.
- UV light will cause fading to some components and fittings. A cover is recommended to reduce the UV degradation.
- Do not leave the rig under tension when not sailing or during storage.
- Care must be taken to support the hull adequately if storing on racking or similar. Any sustained point loading could permanently dent or distort the hull.
- Under covers for LaserPerformance products should be produced from a breathable or semi breathable fabric to allow moisture to evaporate away from the hull. This is essential to prevent damage to the hull skin. Also, the hull should never be left in the under cover wet or damp. A combination of moisture and heat over an extended period can also damage the hull. The under cover is designed to protect the hull when being transported and should be removed when the hull is being stored. Typical damage includes small bubbles or blisters, excessive print through of glass reinforcement, foam or wood and color change.
- Rudders and centerboards must never be stored wet in carry/combo bags. This can cause blistering, print through and warpage.
- All our GRP products are designed to be dry sailed. In other words stored on dry land. If you intend to leave your boat on a mooring for any length of time it is essential that you apply an osmosis barrier coat. LaserPerformance can recommend a suitable product.

On Water

- When wearing a trapeze harness, take particular care when climbing on to the centerboard and back into the boat after a capsize. The trapeze harness hook could easily damage the hull or deck.

On Water Towing

- Towing your LaserPerformance product at high speed (10 – 20 knots) behind a rib or power boat can seriously damage the hull. Boats damaged in this manner are not covered by the warranty. LaserPerformance recommends a maximum towing speed of 6 knots.

Safety Afloat

This instruction manual is not a guide to sailing your craft and it should not be considered suitable for the task of learning to sail a boat. Please read the manual before rigging and sailing your Laser 2000.

Before You Go Sailing:

1. Check you are wearing suitable clothing and safety equipment for the conditions and time of year.
2. Always wear a buoyancy aid or life jacket
3. Make sure a third party knows where you are sailing and how many of you are sailing.
4. Check the weather forecast
5. Check the time of high and low tides if applicable.
6. Seek advise on the local conditions if you are sailing in a new area.
7. Always check the condition of your craft before setting off.
8. **Contact with overhead electrical wires could be fatal, exercise Extreme caution when raising the mast launching & sailing.**

On the Water

1. Conform to the sailing rules of the road.
2. Look out for changing weather conditions.
3. Never sail beyond your ability or that of your crew.
4. Be competent in sailing skills and righting techniques.

Owner Information

hull identification number

purchased from date of purchase

contact name phone #

address:

city / state / county zip / postal code

hull color: sail #:

registration information (if applicable)

trailer vin #

license plate number

registration number state / county registered in

insurance information

maintenance



LaserPerformance NORTH AMERICA

300 Highpoint Avenue
Portsmouth, Rhode Island 02871
t +1 800 966 SAIL
f +1 401 683 0990

LaserPerformance EUROPE

Station Works, Long Buckby
Northamptonshire NN6 7PF
United Kingdom
t +44 (0) 1327 841600
f +44 (0) 1327 841601

LaserPerformance ASIA

Room 3415
China Merchants Tower
Shun Tak Centre
No. 168-200 Connaught Road Central
Hong Kong
t +852 2902 2818
f +852 2587 7868

LaserPerformance AUSTRALIA

t +61 (0) 3 9016 4151

LaserPerformance MIDDLE EAST

T5 Middle East LLC
Knotika Marine Mall, Sheikh Zayed Road
PO Box 54070
Dubai, UAE
t +971 (4) 3039 840
f +971 (4) 3039 839

LASERPERFORMANCE.COM

All rights reserved. ©2008 LaserPerformance.
LaserPerformance and associated logos are
trademarks. Laser, SB3, Sunfish, and Dart
are trademarks used under license.
LaserPerformance reserves the right to make
design and/or specification changes to any
of their products as part of their continuous
development program.